

Model LTWS-4

WEIGHING SYSTEM INTEGRATED IN THE FORKS OF A LIFT TRUCK

AUTONOMOUS WEIGHING SYSTEM, OPERATES INDEPENDENTLY FROM THE LIFT TRUCK

NO CABLING, NO MOUNTING, NO ADJUSTMENTS TO THE LIFT TRUCK

HIGH ACCURACY: MAXIMUM ERROR 0.1% OF THE APPLIED WEIGHT; OPTION CLASS OIML III

WEIGHING FORKS ARE LOW AND NARROW: EASY HANDLING OF ALL PALLETS AND CONTAINERS

SUITABLE FOR HEAVY-DUTY APPLICATIONS: TESTED BY 1,000,000 DYNAMIC CYCLES AT 200% OF THE CAPACITY



FUNCTIONS

- ◆ Automatic and manual zero correction
- ◆ Gross / net weighing
- ◆ Automatic tare and manual tare weight entry
- ◆ Totaling with sequence number
- ◆ Error indication in display
- ◆ Automatic switch-off after 30 minutes of non-use
- ◆ Overload protection 200%



Control of incoming goods during unloading

DIMENSIONS in inches

A	Fork length	:	45
B	Fork width	:	5
C	Height of transmitter housing	:	4
D	Height carriage plate	:	16
E	Fork drop *	:	3/4.3
F	Thickness fork + stop bracket	:	2.8
G	Fork height at the tip	:	0.5
H	Width housing (H1/H2)	:	14/12
I	Outside width housing (I1/I2)	:	7.8/6
J	Inside width housing	:	2
K	Height pallet stop	:	4.3
L	Fork height	:	2.2
M	Thickness housing	:	3.2
	Weight, per fork	:	147 Lbs

Tolerances ± 0.1 inch

* to be mentioned with order.

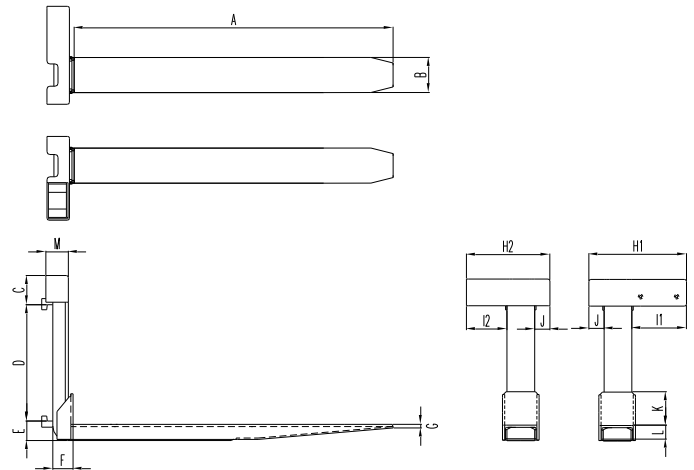

GRADUATION

LTWS-4 : for lift trucks with capacity up to 5000 Lbs
 graduation multi range: 2 Lbs to 2000 Lbs
 5 Lbs to 5000 Lbs

TECHNICAL SPECIFICATIONS

Max. inaccuracy	:	0.1% of applied weight
Display	:	LCD, digit height 18 mm
Keypad	:	3 function keys, on/off switch
Protection	:	according to NEMA 4
Power supply	:	rechargeable battery module, 12V / 1.2 Ah, including charger
Battery life	:	30 hours
	:	low battery indication
	:	automatic switch off after 30 minutes of non-use



OPTIONS

- NTEP Approved for legal for trade applications
- Higher capacities: 6000 Lbs and 10000 Lbs
- Smaller graduation for more accurate readout (may reduce weighing capacity)
- Extra exchangeable battery modules
- Pivoting indicator for reading display from all angles
- Electronic tilting control
- Other fork lengths



American Forklift Scales LLC

4804 Granite Drive
 Building F-3, Unit 293
 Rocklin, California 95677 USA

Tel: 888-640-2725

<http://www.americanforkliftscales.com/>