

# *MP-20*

## *Thermal Printer*

# Setup & Operation Manual

Revision 1.1  
February 20, 2003

! 2002-2003 Transcell Technology, Inc.

Contents subject to change without notice.

Transcell Technology, Inc.  
975 Deerfield Parkway  
Buffalo Grove, IL 60089  
Tel (847) 419-9180  
Fax (847) 419-1515  
E-mail: [transcell@transcell.net](mailto:transcell@transcell.net)  
Web: [www.transcell.net](http://www.transcell.net)

## IMPORTANT SAFETY INSTRUCTIONS

- \* Read all of these instructions and save them for later reference.
- \* Follow all warnings and instructions marked on the product.
- \* Unplug this product from the wall outlet before cleaning. Do not use liquid or aerosol cleaners. Use a damp cloth for cleaning.
- \* Do not use this product near water.
- \* Do not place this product on an unstable cart, stand or table. The product may fall, causing serious damage to the product.
- \* Slots and openings on the housing and the back or bottom are provided for ventilation. To ensure reliable operation of the product and to protect it from overheating, do not block or cover these openings. Placing the product on a bed, sofa, rug or a similar surface, can block the openings. This product should never be placed near or over a radiator or heat register. This product should not be placed in a built-in installation unless proper ventilation is provided.
- \* This product should be operated from the type of power source indicated on the marking label. If you're not sure of the type of power available, consult your dealer or local power company.
- \* Do not allow anything to rest on the power cord. Do not locate this product where the cord will be walked on.
- \* If an extension cord is used with this product, make sure that the total of the ampere ratings on the products plugged into the extension cord do not exceed the extension cord ampere rating. Also, make sure that the total of all products plugged into the wall outlet does not exceed 15 amperes.
- \* Never push objects of any kind into this product through housing slots as they may touch dangerous voltage points or short out parts that could result in a risk of fire or electric shock. Never spill liquid of any kind on the product.
- \* Except as explained elsewhere in this manual, don't attempt to service this product yourself. Opening and removing those covers that are marked "Do Not Remove" may expose you to dangerous voltage points or other risks. Refer all servicing on those compartments to service personnel.
- \* Unplug this product from the wall outlet and refer servicing to qualified service personnel under the following conditions:
  - A. When the power cord or plug is damaged or frayed
  - B. If liquid has been spilled into the product.
  - C. If the product has been exposed to rain or water.
  - D. If the product does not operate normally when the operating instructions are followed. Adjust only those controls that are covered by the operating instructions since improper adjustment of other controls may result in damage and will often require extensive work by a qualified technician to restore the product to normal operation.
  - E. If the product has been dropped or the housing has been damaged.
  - F. If the product exhibits a distinct change in performance, indicating a need for service.

## **1. INTRODUCTION**

The MP-20 is a thermal printer suitable for use with various data communication devices.

This product is extremely compact and features extensive functions suited for a wide range of applications. Please read this manual thoroughly to understand the printer before use.

### **1.1 Features**

1. Compact desktop thermal printer
2. Light weight
3. High speed printing
4. Low power consumption

### **1.2 Accessories**

The following attachments are included in this set aside from the printer itself. Please confirm.

Paper roll (1 roll)

AC adapter (1unit)

User's manual (1 booklet)

Interface Cable

## 2. TYPE CLASSIFICATIONS

### 2.1 Type

The product is categorized according to the naming plan indicated below.

#### MP-20

Model Name

Number of columns (default font)

20 : 20 columns/384 dots per line

### 2.2 AC adapter

Please use the exclusive adapter indicated below.

250115288 (AC 100-240V)

### 2.3 Specifications

Printing method	Thermal dot line printing
Printing width	48 mm
Number of dots/line	384
Dots density	8 dots/mm
Printing speed	18 mm/second <sup>1</sup>
Feeding speed	24 mm/second
Standard paper roll size (W x L)	57 mm× 3600 mm (Thermal) Dia = 57 mm
Interface	Serial Interface (RS-232C) Baud Rate, 9600 Data Bits, 8 Parity, None Stop Bits, 1
Power	DC9V / 2.8A
Current consumption	Printing: 800 mA Feeding: 300 mA Stand By: 80 mA
Weight	Approx. 360g (Paper roll excluded)
Dimension (W x D x H)	120 mm × 170 mm × 90 mm
Operation temp.	0 to 50 C°
Storage temp.	-25 to 65 C°
Fonts available	Arial Narrow 14, Arial Narrow 20, Arial 14, Arial 20, Lucida 16, Courier 20
Default font	Lucida 16
Barcode	Code 39
Max. Printable label size (W x L)	50 mm × 100 mm
Error conditions detected	Paper out, Head up, Overheat

<sup>1</sup> Version 1.06 or higher only. Lower versions print at 10 mm/second.

### 3. EXTERNAL APPEARANCE AND PART DESCRIPTIONS

#### 3.1 External Appearance

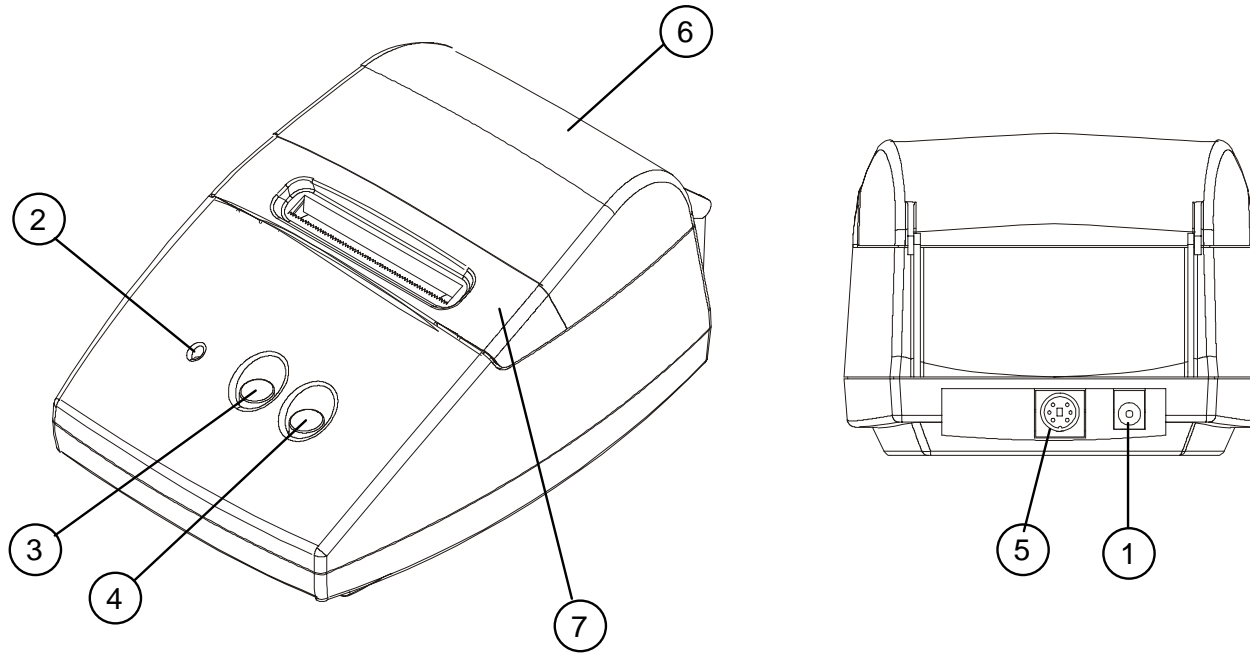

#### 3.2 Part Descriptions

1. DC Power Jack: Insert one end of the enclosed AC adapter here.
2. Power/Status Lamp: Lit when power is turned ON and goes out when turned OFF. Also used to indicate system status. See Section 3.3.
3. CLR Key: Use this key to clear a steady Red Status condition.
4. LF/FF Key: Paper is fed by one line (LF) when key is pressed and released. Paper is continuously fed (FF) when key is pressed and held.

5. Interface Connector: Printer is connected to various hosts via cables. Please ensure that both the printer and the host are turned off before connecting.
6. Printer Cover: Opened to replace paper roll.
7. Print Head Cover: Removed to replace paper roll.

### 3.2 System Status

Lamp Condition	System Status	Description	Action
Steady Green	READY	System ready to accept any command and data input	Send command or data to printer
Flashing Green	PROCESSING	System is processing a command(s)	Wait for process to finish
Steady Red	CMDERR	Command format error, or command/data buffer overflow	Clear error state by pressing CLR key, and then resend all commands after the one that caused the error
Flashing Red	SYSERR	System error. May result from one of the following reasons: Paper out, head in up position, or over heat condition	Check paper, printer head, or wait a while for printer to cool down in case of overheat
Amber	PENDING	Task pending. Happens after self-test page has finished	Send command to print test page again, or switch to another mode and then change pending state to Ready

## 4. OPERATION

### 4.1 Connection of the AC Adapter

- (1) Connect interface cable between the printer and data communication device using supplied cable.
- (2) Plug the AC adapter into the DC power jack on the printer.
- (3) Plug of the AC adapter into a power outlet supplying the designated voltage. (Use of exclusive AC adapter is recommended. Output is DC 9V, 2.8A. Avoid using power sources not conforming to this specification.) The Power/Status Lamp should be green.

### 4.2 Installing the Thermal Paper Roll

**NOTE:** When the printer is shipped from the factory, the paper roll is pre-installed and the printer is ready to operate. Use these instructions when it becomes necessary to replace the paper roll.

- (1) Unplug the AC adapter from the printer.
- (2) Open up the Printer Cover by squeezing at the front to release, then let it fall backwards on its hinges.
- (3) Remove the Print Head Cover by lifting on the tabs towards the back. Once the back tabs are loose, continue to lift the print head cover off and set aside.
- (4) Push the green print head release lever down and towards the rear of the printer.
- (5) Feed new paper roll from the bottom of the print head roller until the paper comes out from the top. Ensure that the paper edge is straight with respect to the roller, i.e. not crooked.
- (6) Push the green print head release lever up and towards the front of the printer.
- (7) Use the thumbscrew on the green print head release lever to feed about an inch of paper from the roll.
- (8) Replace the Print Head Cover by first inserting the front tabs, then installing the rear tabs until the piece is locked into position. Ensure that the paper feeds out from the slot.
- (9) Close the Printer Cover.
- (10) Plug the AC adapter back into the printer.
- (11) After turning ON the printer, press and hold the LF/FF key until 1 or 2 inches of paper is fed out of the printer mechanism.

### 4.3 Self-Test Printing

A self-printing function is incorporated in this product to enable the printer to check itself. This function is triggered by the following procedure.

- (1) Make sure a paper roll is installed.
- (2) Unplug the AC adapter from the printer.
- (3) Press and hold the LF/FF key while plugging the AC adapter back in. Release the LF/FF key after the self-printing operation has started. The printer prints out a test page and then returns to Ready Mode.

**TRANSCELL TECH**  
975 DEERFIELD PKWY  
BUFFALO GROVE, IL 60089  
TEL: (847)419-9160

MP-20 PRINTER TEST  
VERSION 1.06

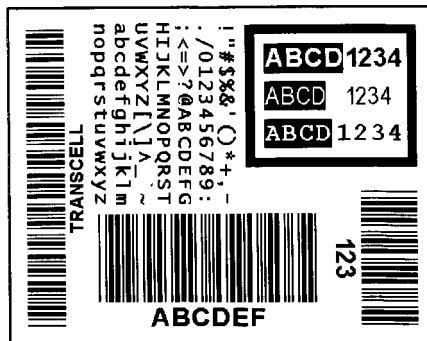

#### **4.4 General Notices**

- (1) Never operate your printer without first loading thermal paper. Any printing without paper or with non-thermal paper may cause damage to printer head.
- (2) Be careful not to drop any foreign matter, such as paper clips, pins, etc. into your printer. These can cause mechanical and/or electrical problems.
- (3) Use your printer on a flat, stable desk.
- (4) Do NOT use an organic solvent (thinner, benzene or the like) to clean the surface of the case.
- (5) Make sure you unplug power of the printer is turned off whenever you do the following.
  - 1) Taking out any foreign matter that was dropped into the printer.
  - 2) Replacing the paper roll.

## 5. SERIAL INTERFACE

### 5.1 Specifications

- 1) Synchronization: Asynchronous
- 2) Baud rate: Fixed at 9,600 Baud / sec
- 3) Word configuration:  
Start bits: 1  
Data bits: 8 (no parity)  
Stop bit: 1
- 4) Signal polarity RS-232C  
\* Mark = Logic "1" (-3 to -12V)  
\* Space = Logic "0" (+3 to +12V)
- 5) Handshaking control: None

### 5.2 Connector Pin Assignment

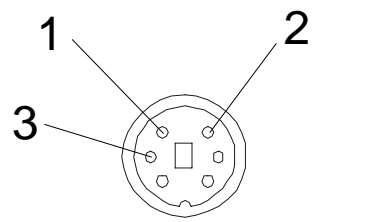
	PIN No.	PIN NAME	FUNCTION
	1 2 3	TXD RXD GND	Transmitted data Received data Signal ground

**Note:** 1. Signals for RS-232C are based on EIA RS-232C level.  
Applicable connector (Mini-DIN connector)  
Printer: Female  
Cable: Male

### 5.3 Description of Input / Output Signal

(1) I / O signals

1) TXD

Serial output data signal.

2) RXD

Serial input data signal. Data is ignored when command format error or overrun error has occurred.

3) GND

Common ground for the circuit.

(2) Data configuration

1) Start bit (1 bit)

2) Data bit (8 bits)

3) Stop bit (1 bit)

(3) Electrical characteristics

1) RS-232C circuit

Input (RXD)

MAX 232 equivalent

Mark = (-8V) : Stop bit

Space = (+8V) : Start bit

## 6. Interface for MP-20 Mini Printer

### 6.1 Working Modes

Name	Description
Character Mode (default):	Prints one line of characters whenever a “carriage return” is received from serial port.
Barcode Mode:	Prints one line of barcodes whenever “carriage return” is received from serial port.
Command-Line Mode:	Accepts predefined command lines from serial port.
Test Page Mode:	Operates a batch of pre-input command lines to print a featured label.

### 6.2 Accepted Commands in Command-Line Mode: (See Appendix B for examples)

Ax,y,rotate,font,reverse,”string”	Print one line of characters
Bx,y,rotate,height,withAscii,”string”	Print one barcode of characters
Dden	Set default density
Ffont	Set default font
N	Clear image buffer
Qheight,width	Set default label size
Lx,y,width,height	Print a rectangular bar
Xx,y,x1,y1,linewidth	Print a rectangular box
Pncp	Print copies of image buffer
Arguments:	
x	start position on x axle
y	start position on y axle
rotate	line orientation
font	font used
reverse	if reverse printed. 0: No; 1: Yes.
string	characters printed
height	size on y direction
withAscii	if readable characters printed. 0: No; 1: Yes.
den	number of density. 0 – 500.
width	size on x direction
x1	end position on x axle
y1	end position on y axle
linewidth	width of line used
ncp	number of copies printed

### 6.3 Fonts Used (See Appendix A for sample print outs)

ARIAL Narrow 14	1
ARIAL 14 Bold	2
ARIAL Narrow 20	3
ARIAL 20 Bold	4
COURIER 20 Bold	5
LUCIDA 16 Bold	6

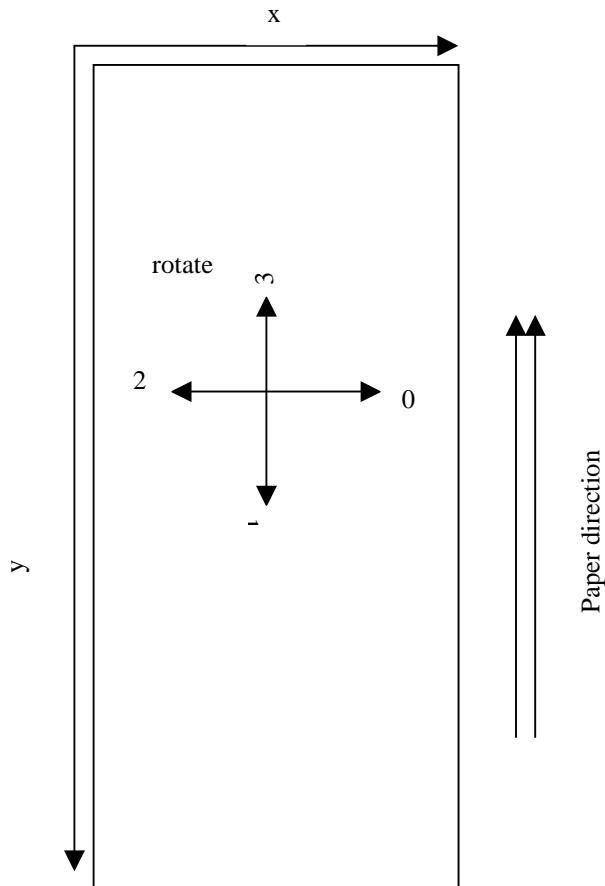

### 6.4 Mode-Setting Commands (in effect for all modes):

[ESC]@[ESC]	Clear command error (function same as CLR key).
[ESC]S[ESC]	Get system status (return status from serial port).
[ESC]M[ESC] <u>mode</u>	Mode switching.
[ESC]F[ESC] <u>lines</u>	Feed lines (in dot).
[ESC]P[ESC]	Process from pending state.

Mode:

- 1 Character mode
- 2 Command Line mode
- 3 Barcode mode
- 4 Test Page mode

\* When input an empty line (only [LF], or [CR][LF]), process [ESC]F[ESC]16.

## 7. CHARACTER SET

### 7.1 Character codes

The printer uses the standard ASCII printable characters plus a few control characters. The control characters are non-printable and are surrounded by brackets.

Character	Hex	Decimal	Description
<BS>	08	8	BACKSPACE (BS)
<HT>	09	9	CHARACTER TABULATION (HT)
<LF>	0A	10	LINE FEED (LF)
<VT>	0B	11	LINE TABULATION (VT)
<FF>	0C	12	FORM FEED (FF)
<CR>	0D	13	CARRIAGE RETURN (CR)
<EC>	1B	27	ESCAPE (ESC)
<SP>	20	32	SPACE
!	21	33	EXCLAMATION MARK
"	22	34	QUOTATION MARK
#	23	35	NUMBER SIGN
\$	24	36	DOLLAR SIGN
%	25	37	PERCENT SIGN
&	26	38	AMPERSAND
'	27	39	APOSTROPHE
(	28	40	LEFT PARENTHESIS
)	29	41	RIGHT PARENTHESIS
*	2A	42	ASTERISK
+	2B	43	PLUS SIGN
,	2C	44	COMMA
-	2D	45	HYPHEN-MINUS
.	2E	46	FULL STOP
/	2F	47	SOLIDUS
0	30	48	DIGIT ZERO
1	31	49	DIGIT ONE
2	32	50	DIGIT TWO
3	33	51	DIGIT THREE
4	34	52	DIGIT FOUR
5	35	53	DIGIT FIVE
6	36	54	DIGIT SIX
7	37	55	DIGIT SEVEN
8	38	56	DIGIT EIGHT
9	39	57	DIGIT NINE
:	3A	58	COLON
;	3B	59	SEMICOLON
<	3C	60	LESS-THAN SIGN
=	3D	61	EQUALS SIGN
>	3E	62	GREATER-THAN SIGN
?	3F	63	QUESTION MARK
@	40	64	COMMERCIAL AT
A	41	65	LATIN CAPITAL LETTER A
B	42	66	LATIN CAPITAL LETTER B
C	43	67	LATIN CAPITAL LETTER C
D	44	68	LATIN CAPITAL LETTER D
E	45	69	LATIN CAPITAL LETTER E
F	46	70	LATIN CAPITAL LETTER F

G	47	71	LATIN CAPITAL LETTER G
H	48	72	LATIN CAPITAL LETTER H
I	49	73	LATIN CAPITAL LETTER I
J	4A	74	LATIN CAPITAL LETTER J
K	4B	75	LATIN CAPITAL LETTER K
L	4C	76	LATIN CAPITAL LETTER L
M	4D	77	LATIN CAPITAL LETTER M
N	4E	78	LATIN CAPITAL LETTER N
O	4F	79	LATIN CAPITAL LETTER O
P	50	80	LATIN CAPITAL LETTER P
Q	51	81	LATIN CAPITAL LETTER Q
R	52	82	LATIN CAPITAL LETTER R
S	53	83	LATIN CAPITAL LETTER S
T	54	84	LATIN CAPITAL LETTER T
U	55	85	LATIN CAPITAL LETTER U
V	56	86	LATIN CAPITAL LETTER V
W	57	87	LATIN CAPITAL LETTER W
X	58	88	LATIN CAPITAL LETTER X
Y	59	89	LATIN CAPITAL LETTER Y
Z	5A	90	LATIN CAPITAL LETTER Z
[	5B	91	LEFT SQUARE BRACKET
\	5C	92	REVERSE SOLIDUS
]	5D	93	RIGHT SQUARE BRACKET
^	5E	94	CIRCUMFLEX ACCENT
_	5F	95	LOW LINE
`	60	96	GRAVE ACCENT
a	61	97	LATIN SMALL LETTER A
b	62	98	LATIN SMALL LETTER B
c	63	99	LATIN SMALL LETTER C
d	64	100	LATIN SMALL LETTER D
e	65	101	LATIN SMALL LETTER E
f	66	102	LATIN SMALL LETTER F
g	67	103	LATIN SMALL LETTER G
h	68	104	LATIN SMALL LETTER H
i	69	105	LATIN SMALL LETTER I
j	6A	106	LATIN SMALL LETTER J
k	6B	107	LATIN SMALL LETTER K
l	6C	108	LATIN SMALL LETTER L
m	6D	109	LATIN SMALL LETTER M
n	6E	110	LATIN SMALL LETTER N
o	6F	111	LATIN SMALL LETTER O
p	70	112	LATIN SMALL LETTER P
q	71	113	LATIN SMALL LETTER Q
r	72	114	LATIN SMALL LETTER R
s	73	115	LATIN SMALL LETTER S
t	74	116	LATIN SMALL LETTER T
u	75	117	LATIN SMALL LETTER U
v	76	118	LATIN SMALL LETTER V
w	77	119	LATIN SMALL LETTER W
x	78	120	LATIN SMALL LETTER X
y	79	121	LATIN SMALL LETTER Y
z	7A	122	LATIN SMALL LETTER Z
{	7B	123	LEFT CURLY BRACKET
	7C	124	VERTICAL LINE

}	7D	125	RIGHT CURLY BRACKET
~	7E	126	TILDE
<DT>	7F	127	DELETE (DEL)

## 8. EXTERNAL DIMENSIONS

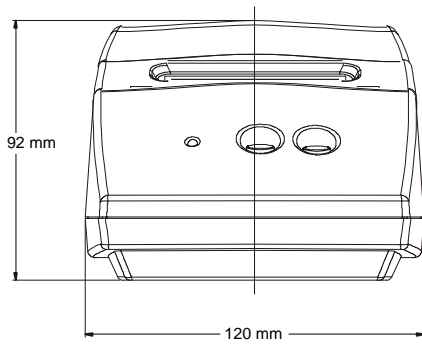
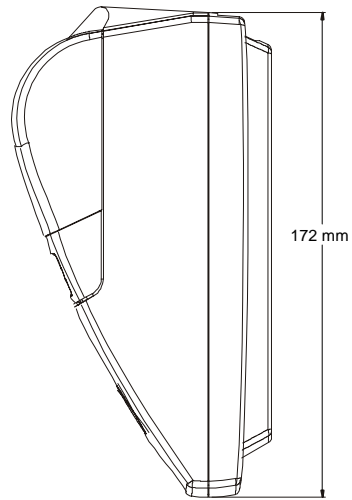
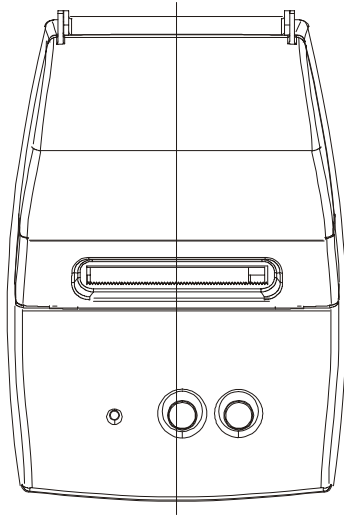

## Appendix A. FONT SAMPLE PRINT OUTS

### Font 1: Arial Narrow 14

---

Font 1: Arial Narrow 14  
ABCDEFGHIJKLMNOPQRSTUVWXYZ  
abcdefghijklmnopqrstuvwxyz  
0123456789 !"\$%&'()\*+,-./:;<=>?@[ ]^\_`{|}~

### Font 2: Arial 14

---

Font 2: Arial 14  
ABCDEFGHIJKLMNOPQRSTUVWXYZ  
abcdefghijklmnopqrstuvwxyz012345678  
9 !"\$%&'()\*+,-./:;<=>?@[ ]^\_`{|}~

### Font 3: Arial Narrow 20

---

Font 3: Arial Narrow 20  
ABCDEFGHIJKLMNOPQRSTUVWXYZ  
YZabcdefghijklmnopqrstuvwxyz  
0123456789 !"\$%&'()\*+,-./:;<=>?@[ ]  
|^\_`{|}~

---

**Font 4: Arial 20**

---

Font 4: Arial 20  
ABCDEFGHIJKLMNOPQRSTUVWXYZ  
TUVWXYZabcdefghijklmnopqrstuvwxyz  
0123456789 !"#\$%&'()\*+,-./:;<=>?@[\\]^\_`{|}~

---

**Font 5: Courier 20**

---

Font 5: Courier 20  
ABCDEFGHIJKLMNOPQRSTUVWXYZ  
VWXYZabcdefghijklmnopqrstuvwxyz  
0123456789 !"#\$%&'()\*+,-./:;<=>?@  
[\\]^\_`{|}~

---

**Font 6: Lucida 16 (Default)**

---

Font 6: Lucida 16  
ABCDEFGHIJKLMNOPQRSTUVWXYZ  
Zabcdefghijklmnopqrstuvwxyz  
0123456789 !"#\$%&'()\*+,-  
./:;<=>?@[\\]^\_`{|}~

---

## Appendix B. COMMAND SET EXAMPLES

Q250,384␣	Set label size: width 384, length 200 (points).
D500␣	Set density 500.
B20,10,0,40,0,"CODE 39"␣	Draw code-39 barcode of the string "CODE 39". Start at coordinate x:20, y: 10; direction 0; barcode height 40; no human readable text.
B20,80,0,60,1,"Readable"␣	Draw code-39 barcode of the string "Readable". Start at coordinate x:20, y: 80; direction 0; barcode height 60; has human readable text.
B20,190,0,25,1,"narrow"␣	Draw code-39 barcode of the string "narrow". Start at coordinate x:20, y: 190; direction 0; barcode height 25; has human readable text.
P1␣	Print one label.

Result:

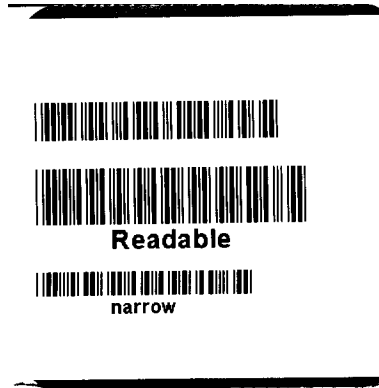

Continued =>

Q140,384	Set label size: width 384, length 140 (points).
D500	Set density 500.
X10,10,373,130,20	Draw a box. Start at coordinate x:10, y:10; end at x:373, y:130; thickness 20 points.
A50,40,0,5,0,"Normal Text"	Write normal text "Normal Text", start at coordinate x:50, y:40; direction 0; use font Courier-20 (font 5).
A50,70,0,5,1,"Reverse Text"	Write reversed text "Reverse Text", start at coordinate x:50, y:70; direction 0; use font Courier-20 (font 5).
P1	Print one label.

Result:

